

DETAIL A

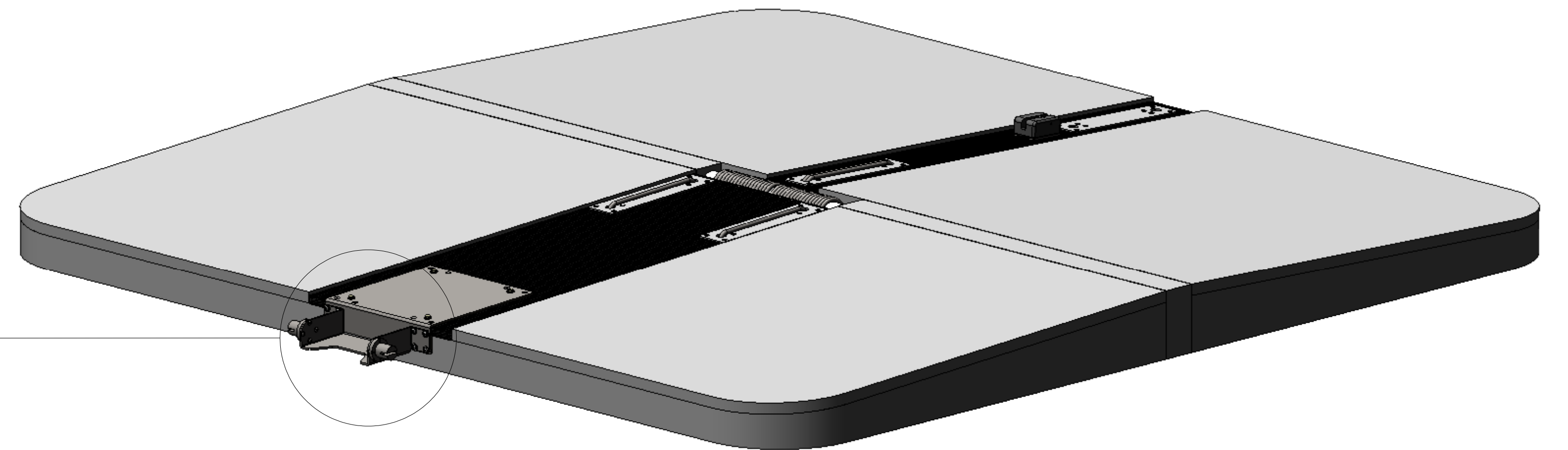
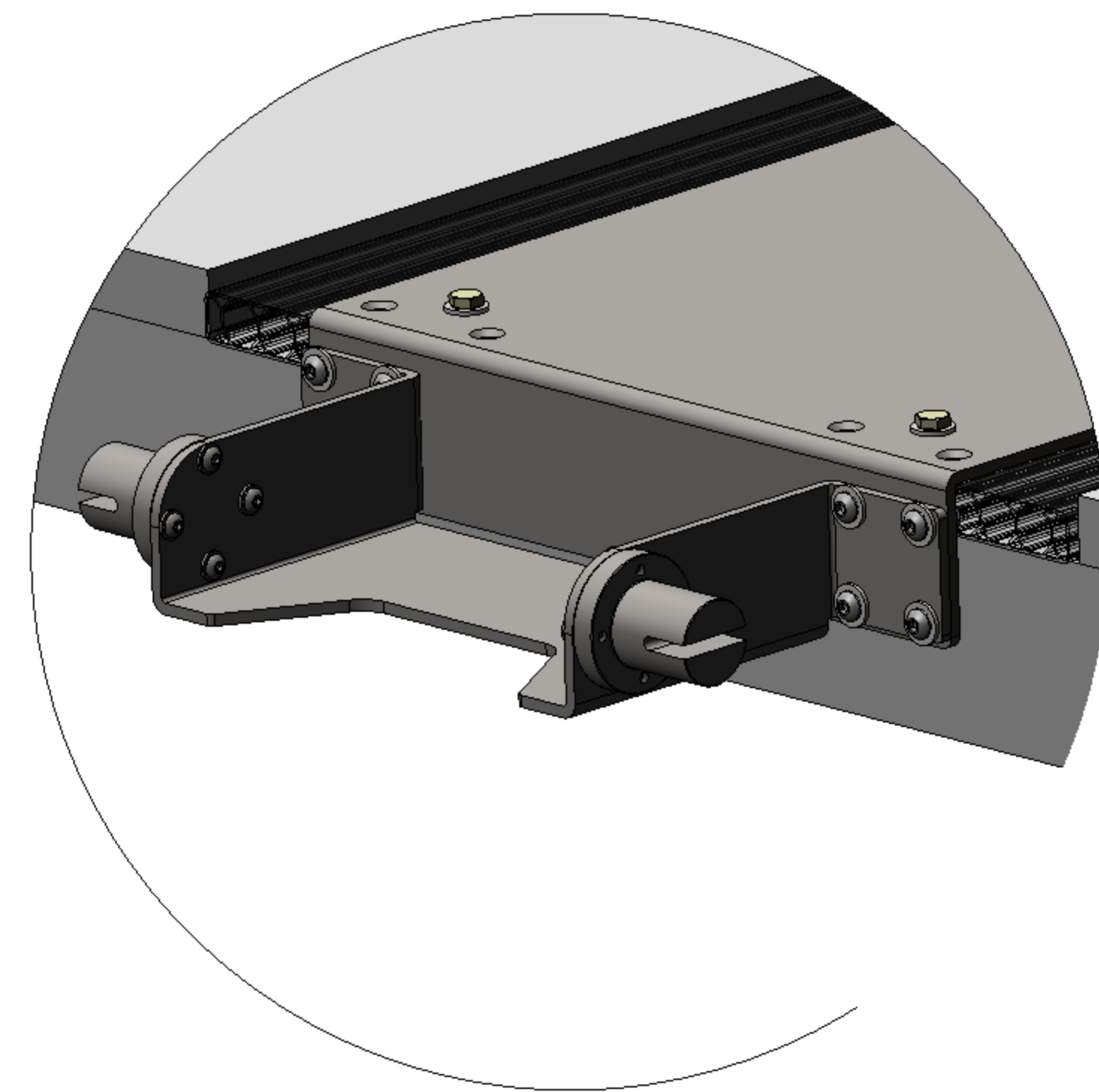
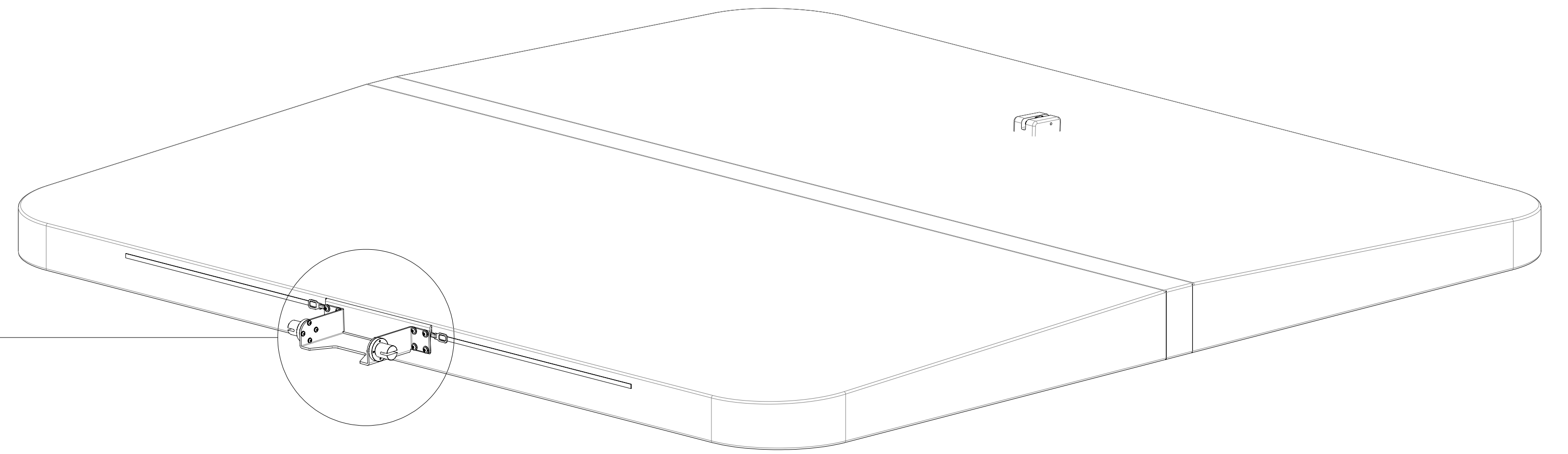
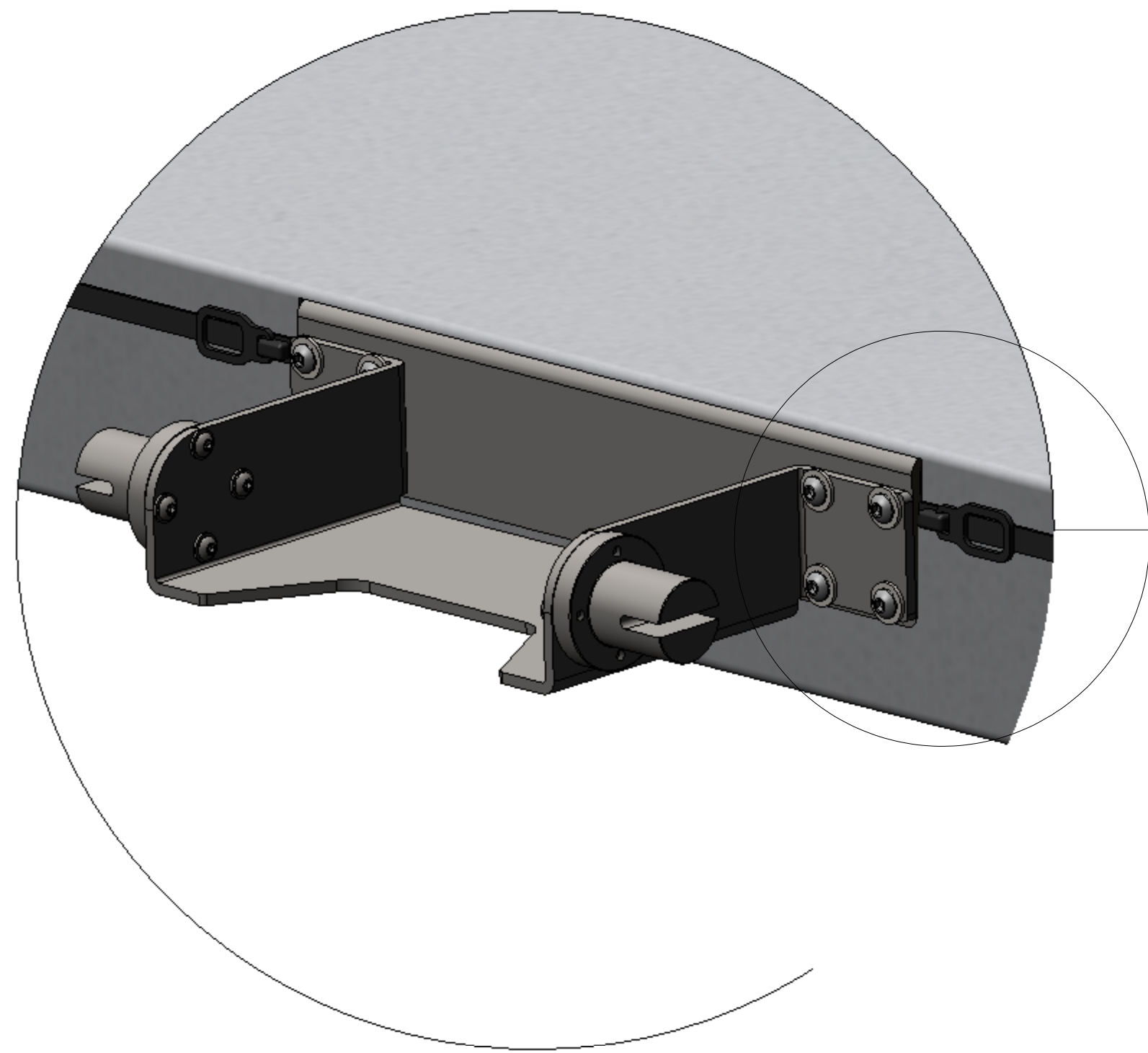

DETAIL B
VINYL REMOVED

THE INFORMATION DISCLOSED HEREIN CONTAINS PROPRIETARY RIGHTS OF NEROK LLC, AND IS NOT TO BE REPRODUCED, USED OR DISCLOSED TO OTHERS FOR MANUFACTURE OF ANY OTHER PURPOSE EXCEPT AS SPECIFICALLY AUTHORIZED IN WRITING BY NEROK LLC.

DRAWN BY <i>D. COOKE</i> 21 June, 16 DATE DESIGN APPROVED BY DATE TOLERANCE APPROVED BY DATE CONTROLS APPROVED BY DATE ELECTRICAL APPROVED BY DATE PNEUMATIC APPROVED BY DATE	UNLESS OTHERWISE SPECIFIED INTERPRET DRAWING PER MIL-STD-100 DIMENSIONING AND TOLERANCING PER ANSI Y14.5 - 1982 ALL DIMENSIONS APPLY AFTER HEAT TREAT AND PLATING REMOVE ALL BURRS AND BREAK SHARP EDGES .005 TO .015 FILET RADIUS .005 TO .015 MACHINED SURFACES 125 THREADS PER FED-STD-H28	<table border="1"> <thead> <tr> <th>REV</th> <th>DATE</th> <th>DESCRIPTION</th> <th>REVISED</th> </tr> </thead> <tbody> <tr> <td></td> <td></td> <td></td> <td></td> </tr> </tbody> </table>	REV	DATE	DESCRIPTION	REVISED					<table border="1"> <tr> <td>TOLERANCE</td> <td>X.X ±.05 X.XX ±.015 X.XXX ±.005 X.XXXX ±.0005 ANGLES ±.5</td> </tr> <tr> <td>MATERIAL</td> <td>-</td> </tr> <tr> <td>SIZE</td> <td>-</td> </tr> <tr> <td>HEAT TREAT</td> <td>-</td> </tr> <tr> <td>FINISH</td> <td>-</td> </tr> </table>	TOLERANCE	X.X ±.05 X.XX ±.015 X.XXX ±.005 X.XXXX ±.0005 ANGLES ±.5	MATERIAL	-	SIZE	-	HEAT TREAT	-	FINISH	-	<table border="1"> <tr> <td colspan="2"> NerokLifts LLC </td> </tr> <tr> <td colspan="2"> TITLE COVER - CORE ASSEMBLY SPA COVER LIFT NEROKLIFTS LLC </td> </tr> <tr> <td> DWG NO. NEROK-05-00 </td> <td> SCALE NONE </td> </tr> <tr> <td> SHEET 3 of 3 </td> <td> REV. R </td> </tr> </table>	NerokLifts LLC		TITLE COVER - CORE ASSEMBLY SPA COVER LIFT NEROKLIFTS LLC		DWG NO. NEROK-05-00	SCALE NONE	SHEET 3 of 3	REV. R
REV	DATE	DESCRIPTION	REVISED																											
TOLERANCE	X.X ±.05 X.XX ±.015 X.XXX ±.005 X.XXXX ±.0005 ANGLES ±.5																													
MATERIAL	-																													
SIZE	-																													
HEAT TREAT	-																													
FINISH	-																													
NerokLifts LLC																														
TITLE COVER - CORE ASSEMBLY SPA COVER LIFT NEROKLIFTS LLC																														
DWG NO. NEROK-05-00	SCALE NONE																													
SHEET 3 of 3	REV. R																													